

# Suspension System

WITHOUT INTERMEDIATE JOINT

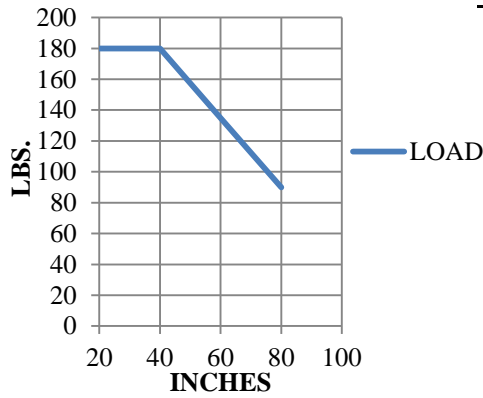

**"LOAD DIAGRAMS"**

WITH INTERMEDIATE JOINT

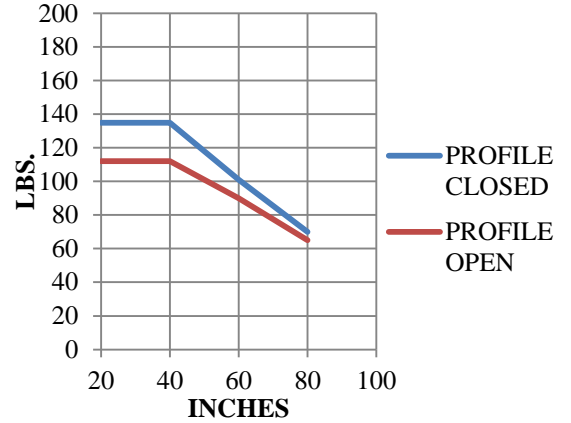

PARTS LIST		
	HARDWARE NAME	TORQUE Inch LBS. 
<b>A</b>	M8 x 50	81 in-lb.
<b>B</b>	M6 x 16	24 in-lb.
<b>C</b>	M4 x 10	12 in-lb.
<b>D</b>	M6	27 in-lb.
<b>E</b>	M10 / 3/8-16	132 in-lb.
<b>F</b>	M5 x 16 w/ Flat Washer	
<b>G</b>	M6 x 22 w/ Flat Washer	

With intermediate joint max. Tube length:

Profile closed:

- 60" distance between wall hinge, top mounted joint and intermediate joint or
  - 60" distance between angle and intermediate joint.
- Complete length max. 80"

Profile open:

- 40" distance between wall hinge, top mounted joint and intermediate joint or
  - 40" distance between angle and intermediate joint.
- Complete length max. 80"

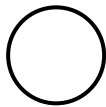
 = Included and Standard Parts

**SCE-SA360C:**

**G  
x4**



**A  
x4**

**ENCLOSURE MOUNTING HOLE PATTERN**

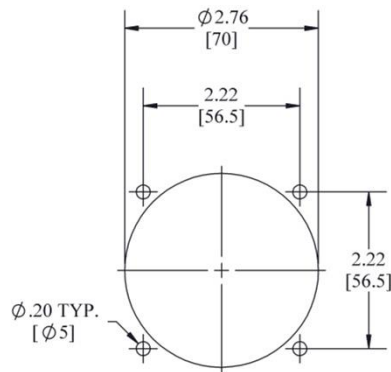

**ROTATION LIMITING PIN INSTALLATION**

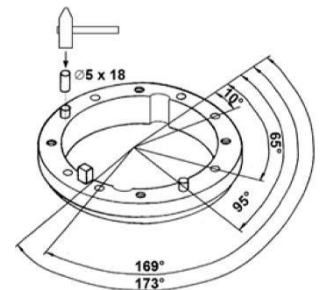

# Suspension System

**SCE-SA320AC:**

**G**  
x4

**A**  
x4

**D**  
x4



**B**

**ENCLOSURE MOUNTING HOLE PATTERN**

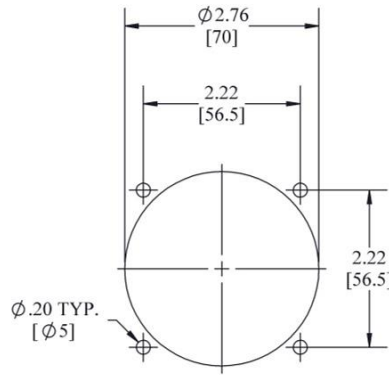

**ROTATION LIMITING PIN INSTALLATION**

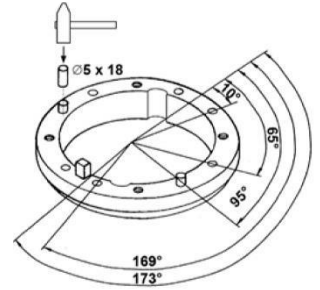

**SCE-SA310TMJ:**

**B**

**A**  
x4

**E**  
x4

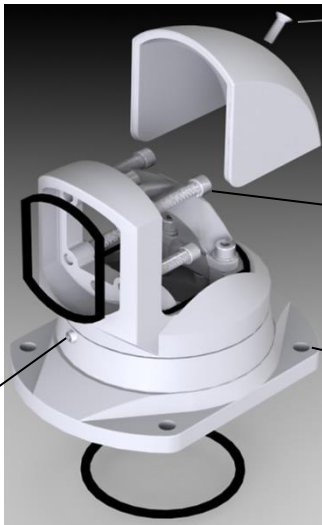

**BASE MOUNTING HOLE PATTERN**

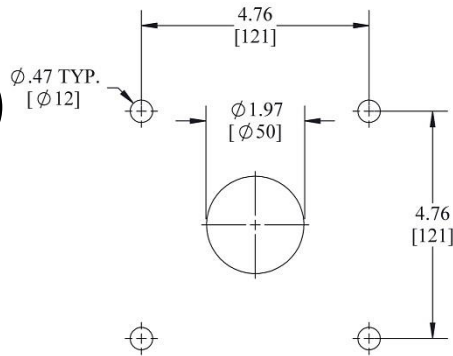

**ROTATION LIMITING SCREW INSTALLATION**

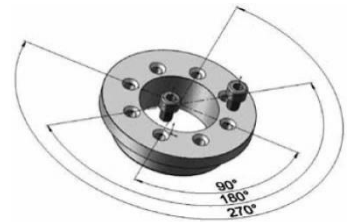

**SCE-SA230WH:**

**B**

**A**  
x4

**E**  
x4

**C**  
x4

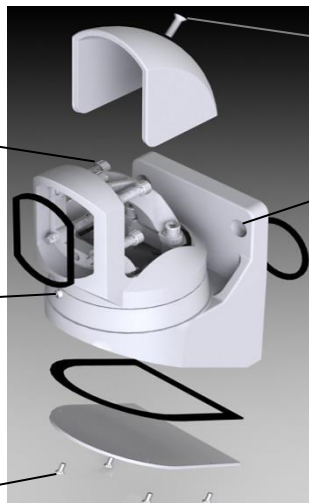

**BASE MOUNTING HOLE PATTERN**

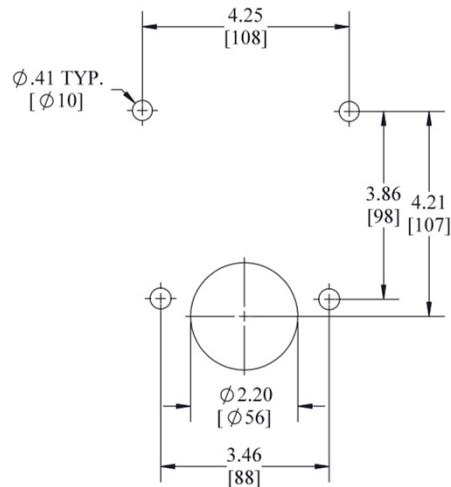

**ROTATION LIMITING SCREW INSTALLATION**

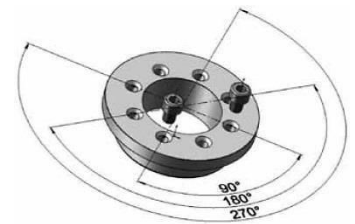

# Suspension System

**SCE-SA310IJ:**  
OR  
**SCE-SA310JD**

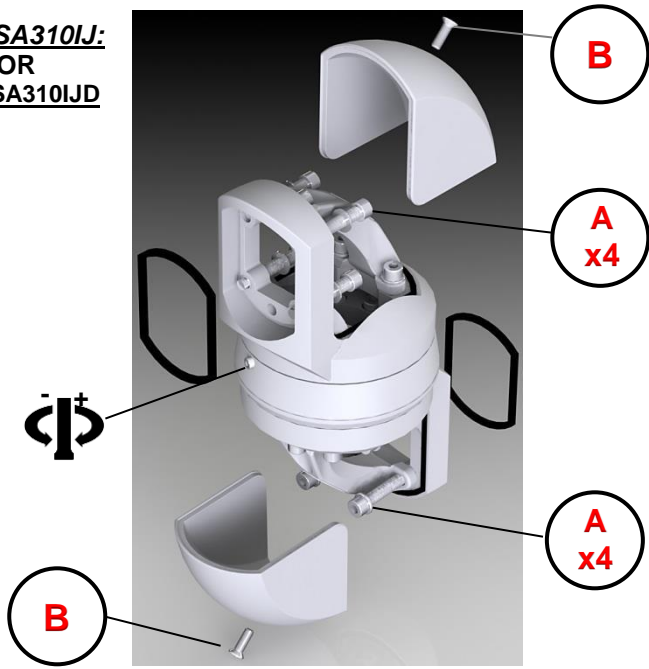

**“SCE-SA310IJ”**

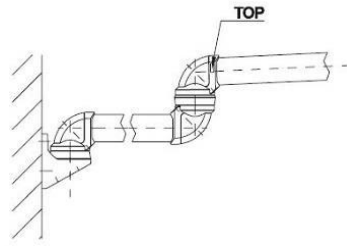

**ROTATION  
LIMITING SCREW INSTALLATION**

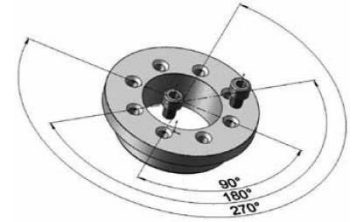

**“SCE-SA310JD”**

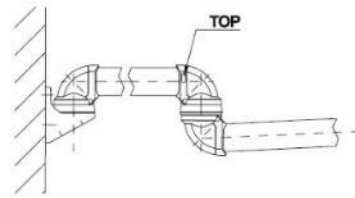

**SCE-SA90A:**

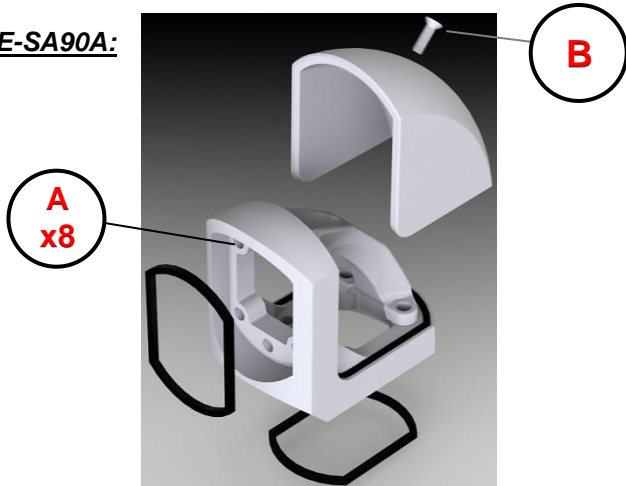

**SCE-SAFFS:**

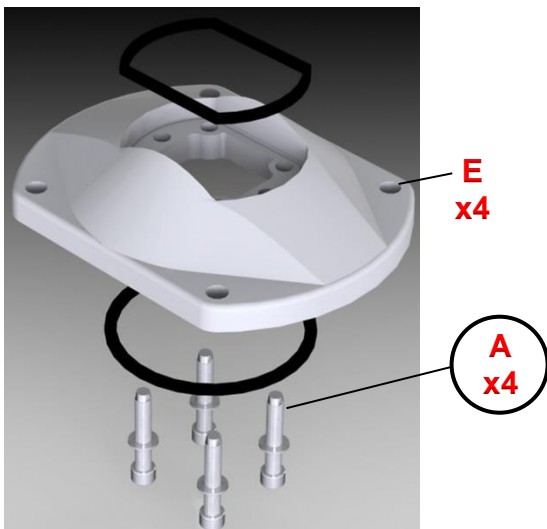

**BASE MOUNTING  
HOLE PATTERN**

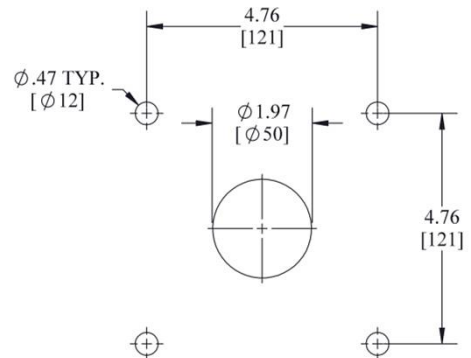

# Suspension System

## SCE-SATFS:

1.8  
**G**  
**x4**

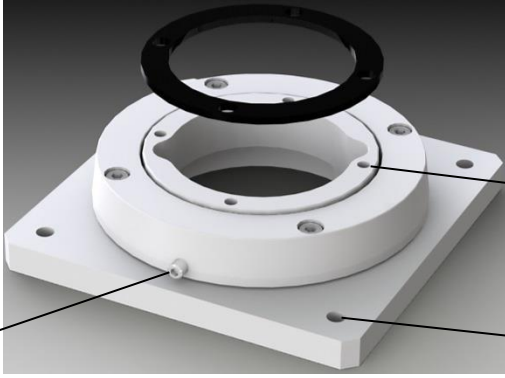

**D**  
**x4**



**D**  
**x4**

ROTATION  
LIMITING PIN INSTALLATION =

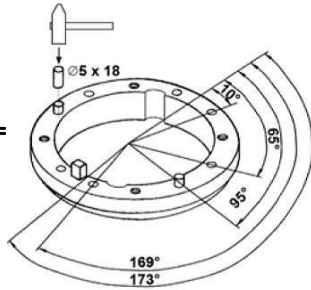

## BASE MOUNTING HOLE PATTERN

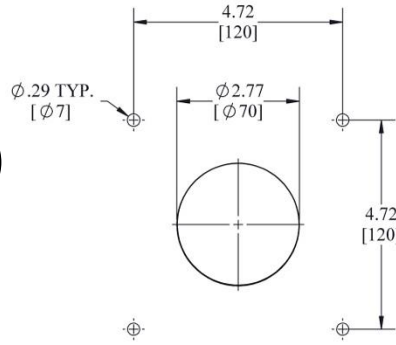

## ENCLOSURE MOUNTING HOLE PATTERN

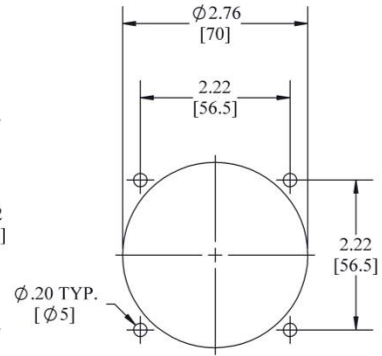

## SCE-SA45IA:

**G**  
**x4**



**D**  
**x4**

**D**  
**x4**

## ENCLOSURE MOUNTING HOLE PATTERN

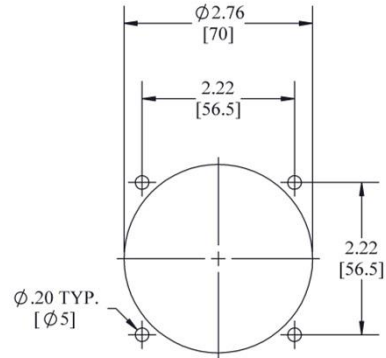

## SCE-SAFC:

**F**  
**x4**

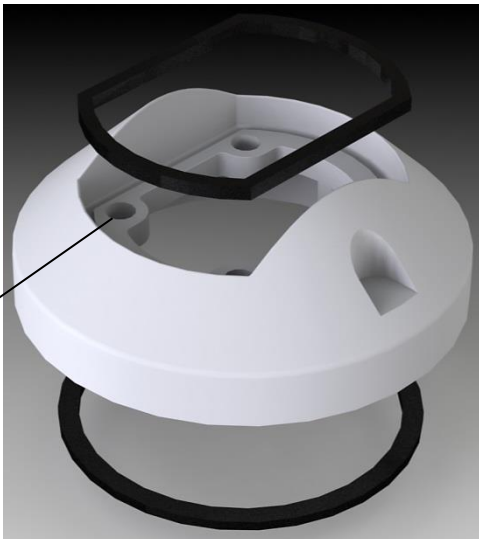

**A**  
**x4**

## ENCLOSURE MOUNTING HOLE PATTERN

